

CANRACK

METAL CENTER SYSTEMS

PAN PICK BAR ORDER FILLING STATION



Material picked from pan to load system



Banding station with impact bars
and bundling yokes

SAFETY

The Canrack Pan Pick Bar Station is an innovative way of achieving high order filling productivity without the high cost of Over-Under Bar Stations.

Pans are brought to the charge end of the accumulating chain conveyor by fork truck or sideloader and placed on holding stands. The sideloader operator then operates hydraulic controls that activate stripper plates that move material up and out of the pan to transfer to the accumulating chain conveyor.

Rounds spill uniformly onto the chain conveyor without manual assistance. Flats and shapes may require some manual assistance to transfer from the pan to the chains. When the order quantity is complete, the sideloader returns the pan to the rack system and then brings the next pan to the station.

Material on the chains are jogged forward to the banding station where items are transferred to impact bars. When complete, the impact bars lower and put the material into bundling yokes to shape the material into a bundle ready for strapping.

QUALITY

PRODUCTIVITY

Overhead mounted pneumatic strappers together with floor mounted strapping reels make for quick and easy strapping by station operator.

Finished orders are removed from the station by overhead crane or fork truck and moved to a shipping accumulation laydown area for truck loading.

Optional scales can be provide complete with digital read-out and printers.

This station represents an economical solution with good productivity for orders volumes in the range of 40 to 100 orders per shift.

Canrack Storage Systems Inc.
6625 Tomken Road, Suite 209, Mississauga, Ont. L5T 2C2
Tel: (905) 564-6250 Fax: (905) 564-6253
E-mail: info@canrack.com Website: www.canrack.com

PAN PICK BAR ORDER FILLING STATION

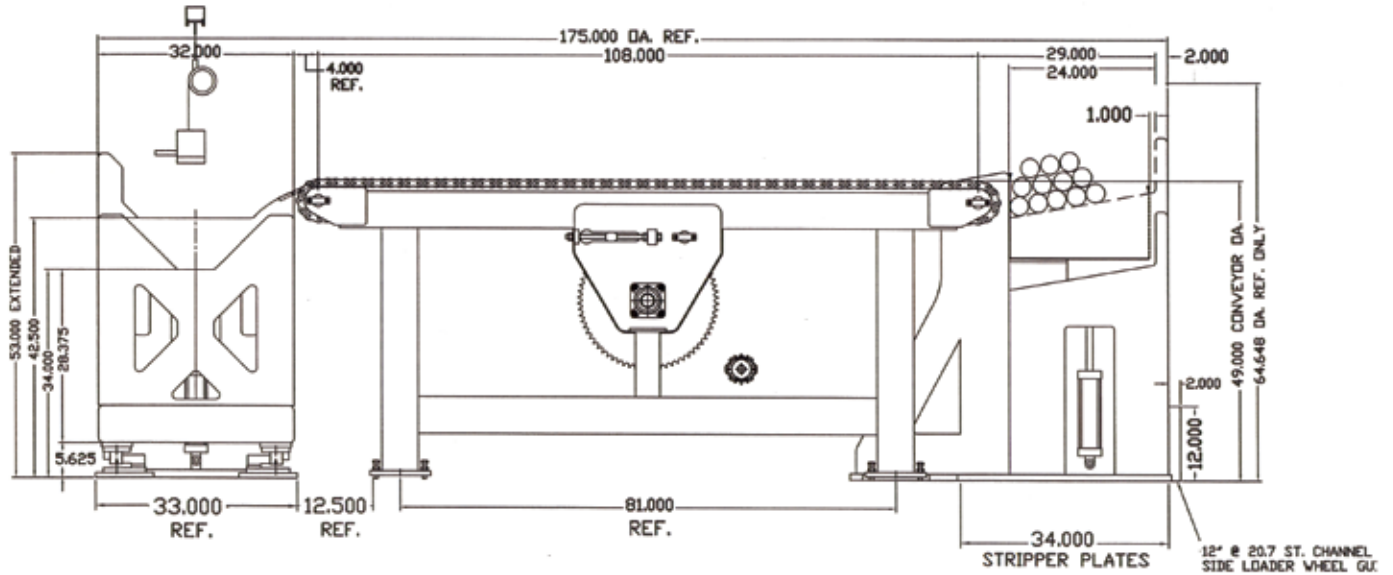

Typical Pan Pick station with accumulation of material for orders feeding impact bars, bundling yokes and packaging station. This provides a buffer between sideloader and packaging increasing productivity



An alternate Pan Pick station with accumulation of finished orders for direct truck loading or transfer to laydown. This provides immediate clearing of the station when an order is finished and is not dependant on crane or fork truck to begin packaging the next order.